

Warden's House, Drury Lane.

Site location plan

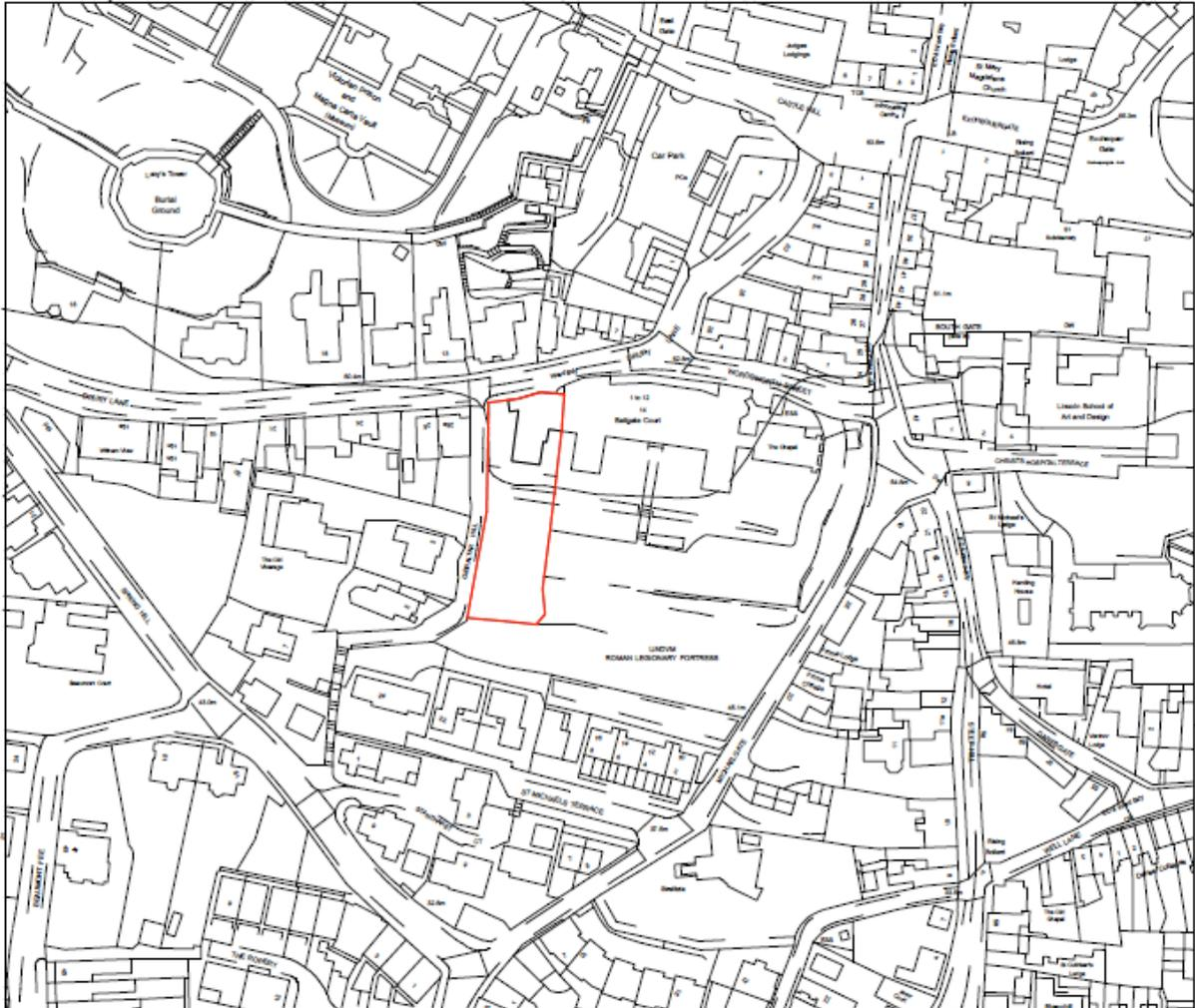

**SITE LOCATION PLAN**

SCALE 1:1250

Do not scale from this drawing. Figured dimensions are taken to structure unless indicated otherwise. All dimensions to be checked on site prior

Site Plan

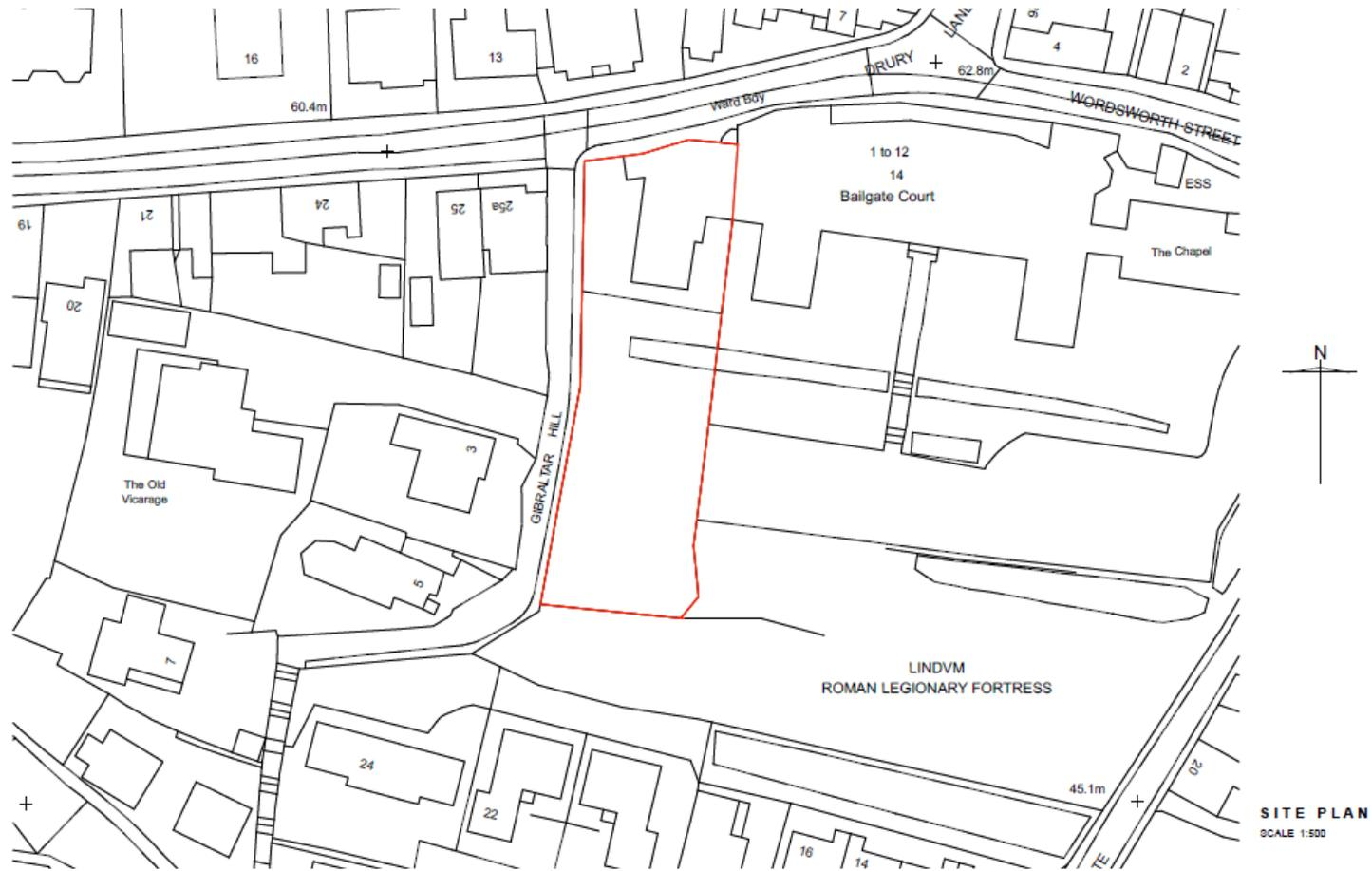

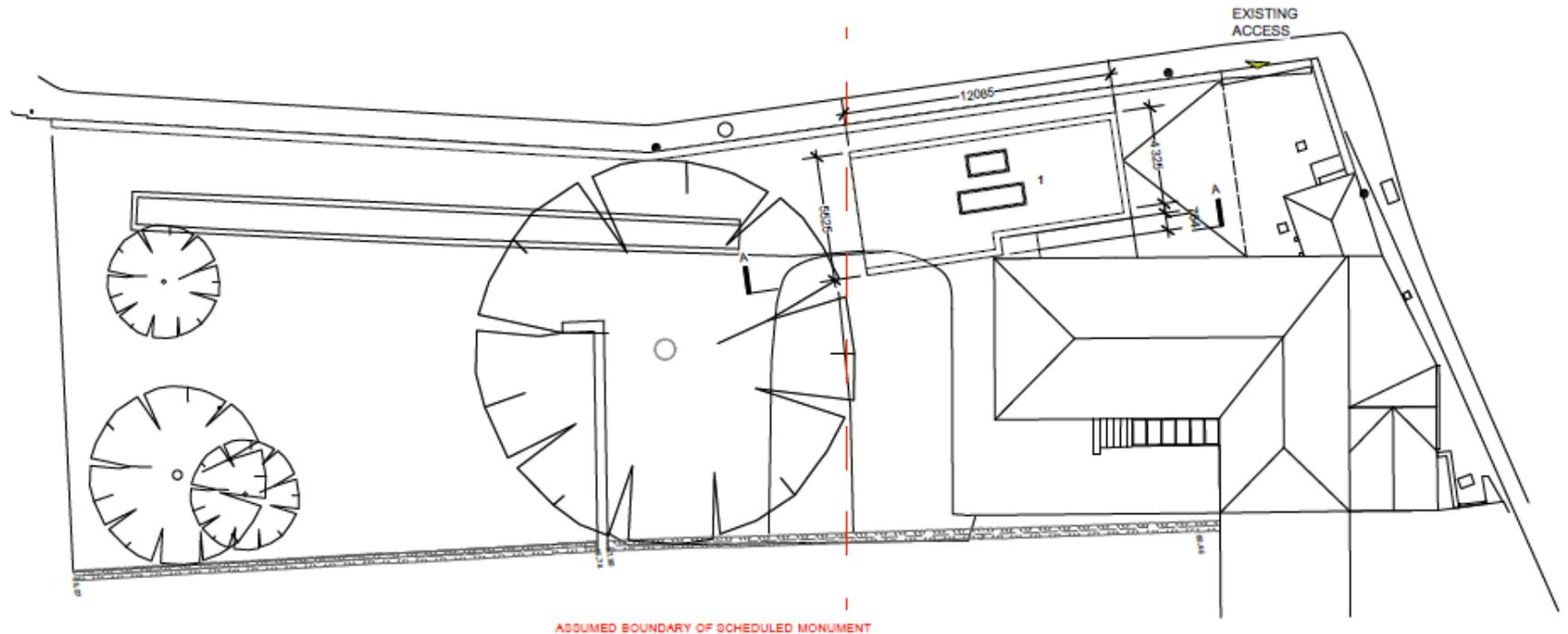

ASSUMED BOUNDARY OF SCHEDULED MONUMENT

1 PROPOSED ANNEX

PROPOSED SITE PLAN  
SCALE: 1:200



**PROPOSED LOWER FLOOR PLAN**  
SCALE 1:100

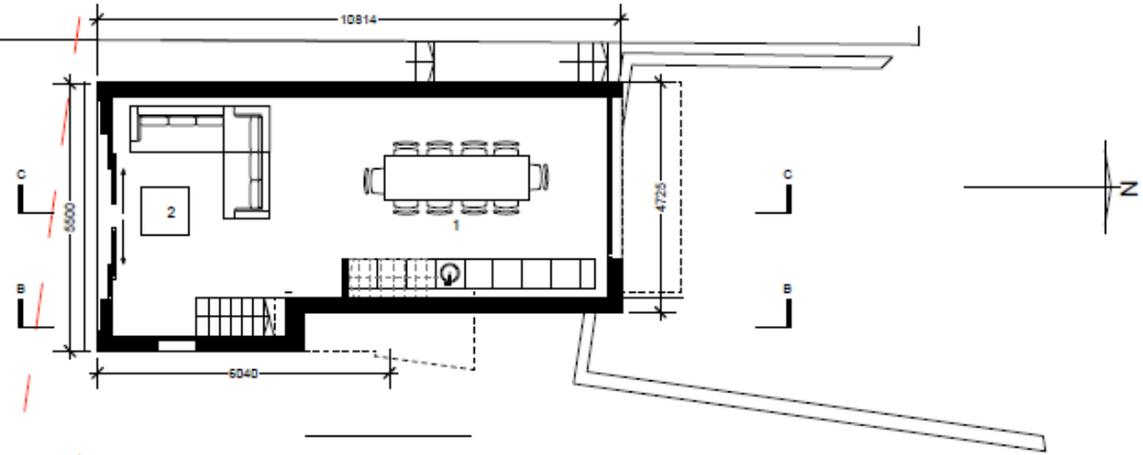

- 1 KITCHEN DINING
- 2 LOUNGE
- 3 LINK TO EXISTING DWELLING
- 4 GYM
- 5 GUEST BEDROOM
- 6 TOILET

**PROPOSED GROUND FLOOR PLAN**  
SCALE 1:100

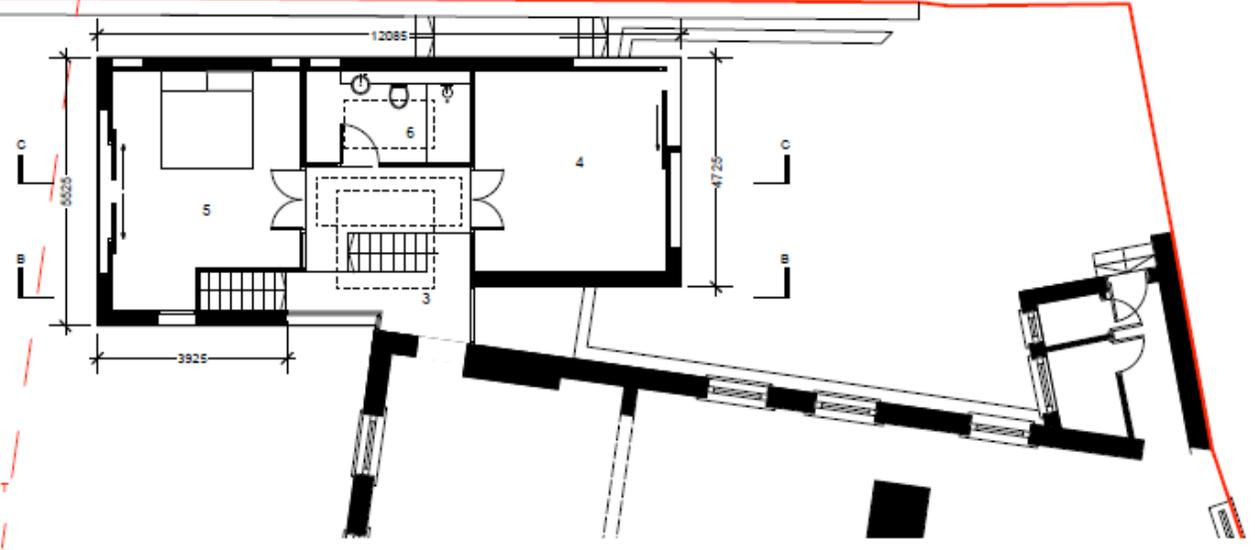

ASSUMED BOUNDARY OF SCHEDULED MONUMENT



**PROPOSED WEST ELEVATION** (Including Chad Varah House, boundary wall and Gibraltar Hill)  
SCALE 1:200





**PROPOSED SOUTH ELEVATION** (Including Chad Varah House)  
SCALE 1:200



PROPOSED NORTH ELEVATION  
SCALE 1:200

PROPOSED NORTH ELEVATION (Including Chad Varah House)  
SCALE 1:200



**PROPOSED EAST ELEVATION** (Including boundry wall and Gibraltar Hill)  
SCALE 1:200



MEMBERS OF THE CITY OF BOSTON, MASSACHUSETTS, REQUEST TO GRANT THE APPLICANT A PERMIT TO CONSTRUCT AND OCCUPY THE PROPOSED BUILDING AS SHOWN ON THE ATTACHED PLANS AND SPECIFICATIONS. THE APPLICANT HAS PROVIDED ALL NECESSARY INFORMATION AND HAS COMPLIED WITH ALL APPLICABLE ORDINANCES AND STATE REGULATORY REQUIREMENTS (E.G., SEWERAGE AND SANITATION).



**PROPOSED SOUTH ELEVATION**  
SCALE 1:100

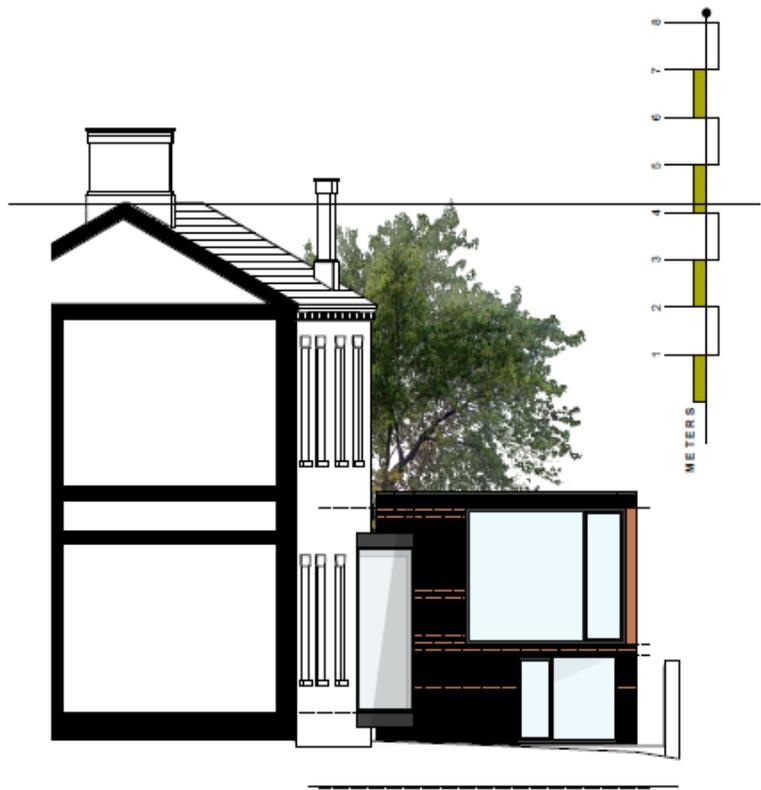

**PROPOSED NORTH ELEVATION**  
SCALE 1:100



240  
240

8  
7  
6  
5  
4  
3  
2  
1  
METERS

**PROPOSED EAST ELEVATION**  
SCALE 1:100







Examples of the use of brickwork, glazing and materials.









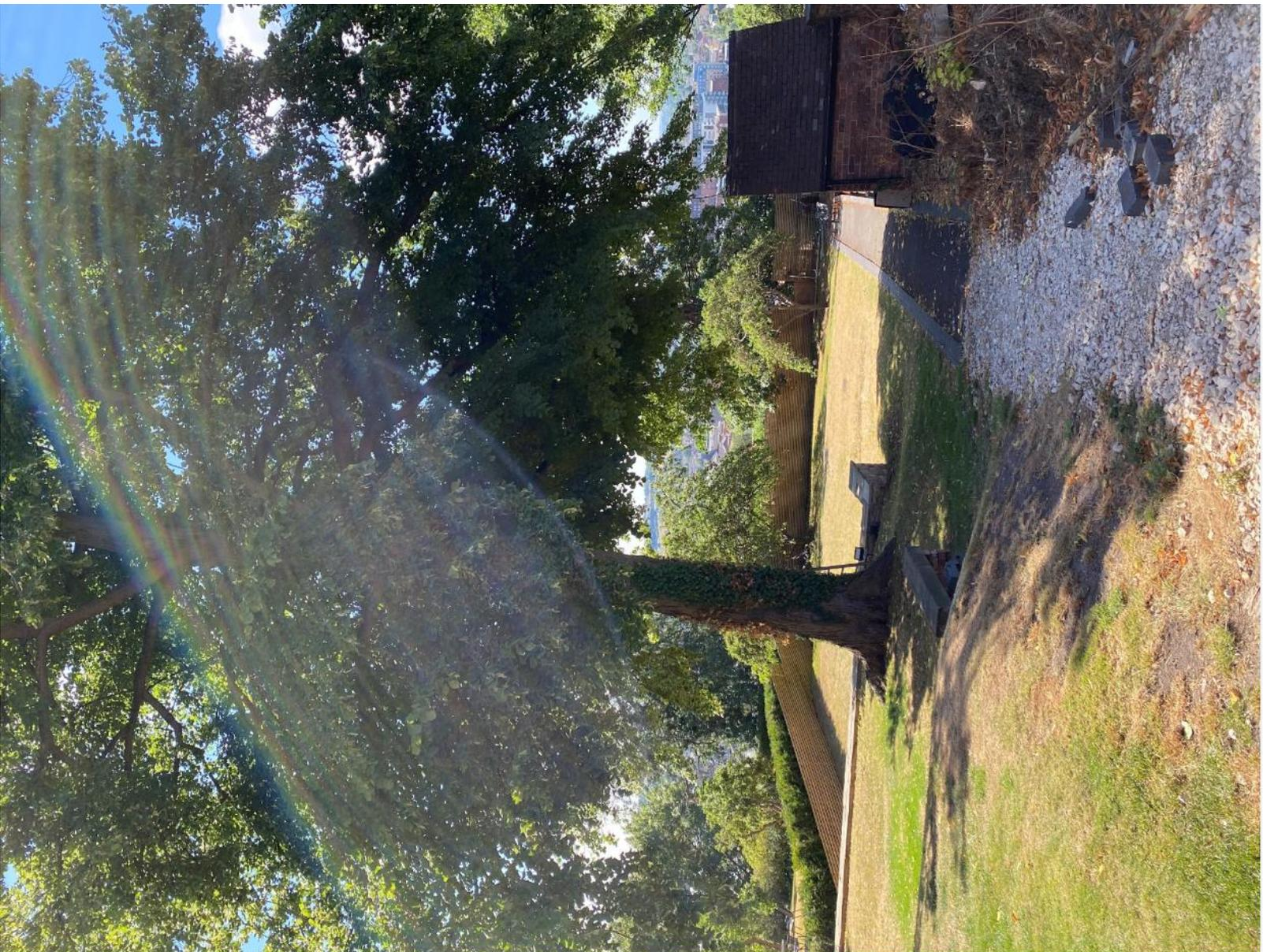



Elevation of previously approved extension